

1 2 3 4 5 6 7 8

A
B
C
D
E
F
G

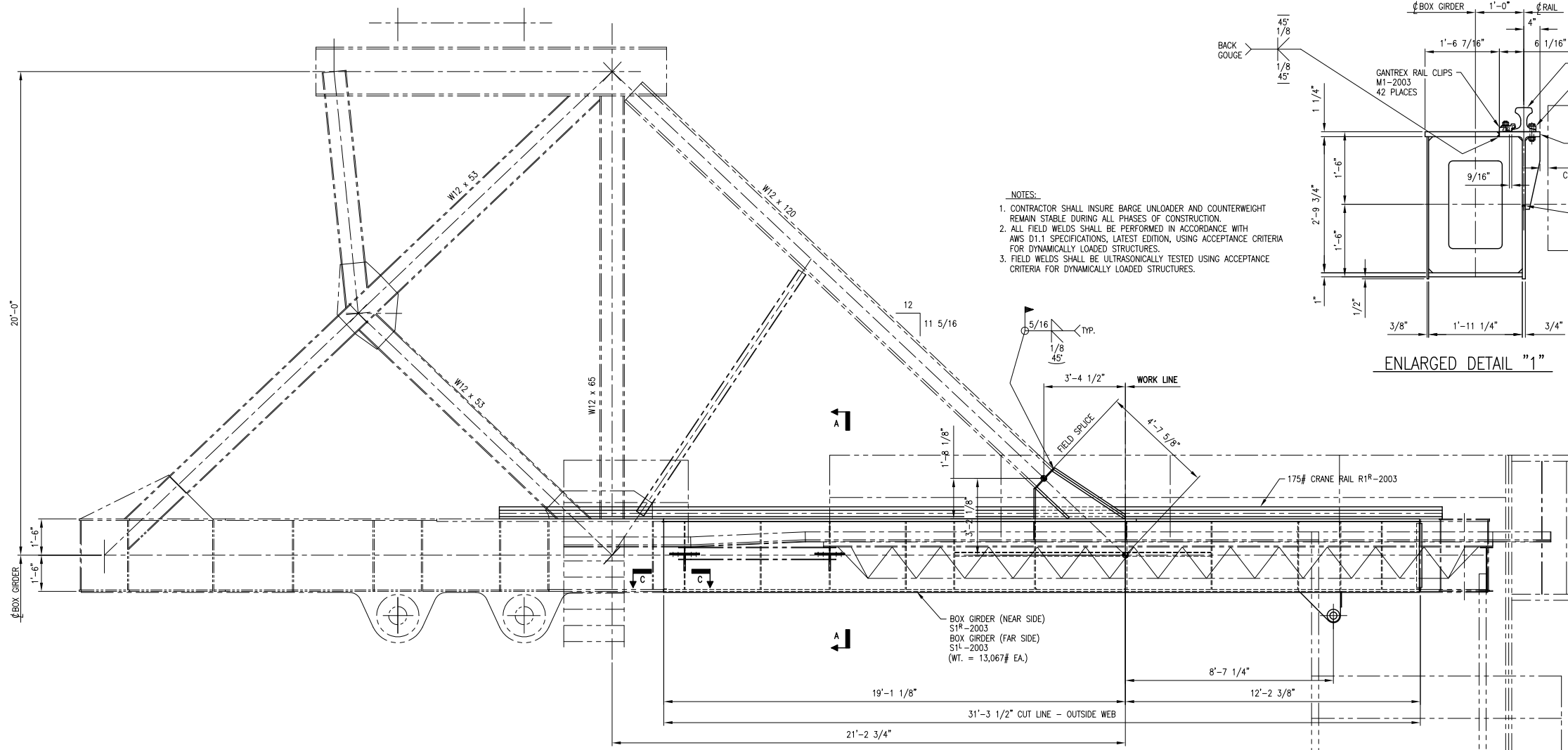

ELEVATION VIEW ~ UNLOADER CANTILEVER SECTION BOX GIRDER REPAIR

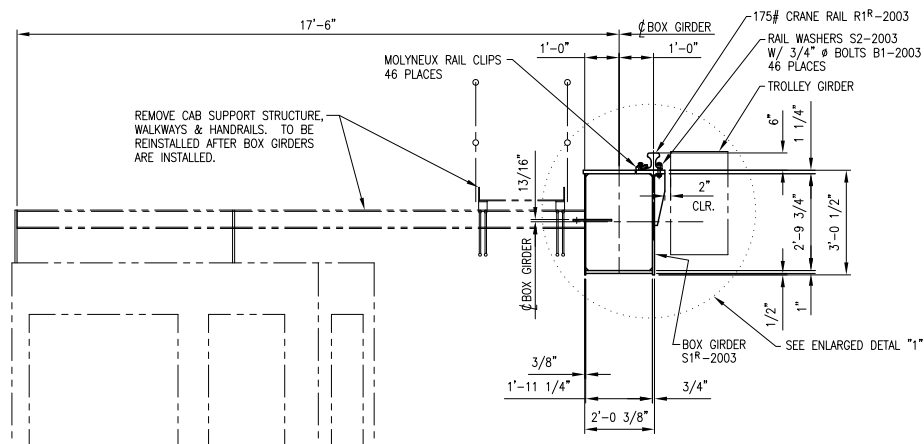

SECTION A-A

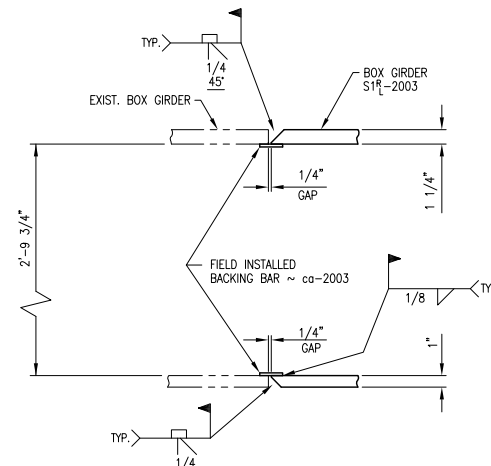

SECTION B-B
TYP. 4 PLACES

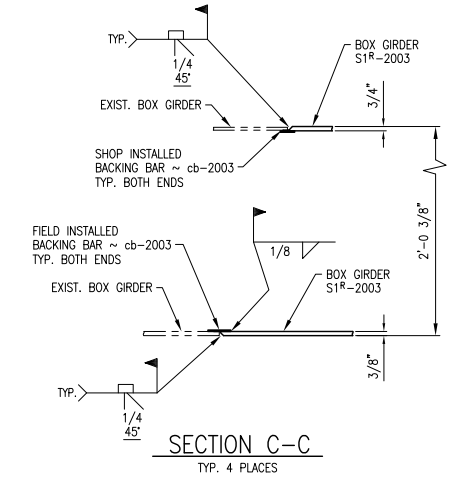

SECTION C-C
TYP. 4 PLACES

WORK THIS DWG. WITH DWG. 2001

		Richmond Engineering Works LLC Pittsburgh, PA 15205	
Drawn By: WKM Date: 07/16/13	Checked: JFM Date: 07/30/13	Approved: JLD Date: 07/31/13	Scale: 3/4"=1'
0 FOR CONSTRUCTION Rev. Description Date Made Chk'd App'd		KENTUCKY UTILITIES GHENT STATION S02567-2002 Rev. 0	
CONTINUOUS BARGE UNLOADER CANTILEVER GIRDER REPAIR			

1 2 3 4 5 6 7 8