

FOR $\Psi > 120^\circ$
EDGE SHALL BE CUT
BACK TO FACILITATE
THROAT THICKNESS

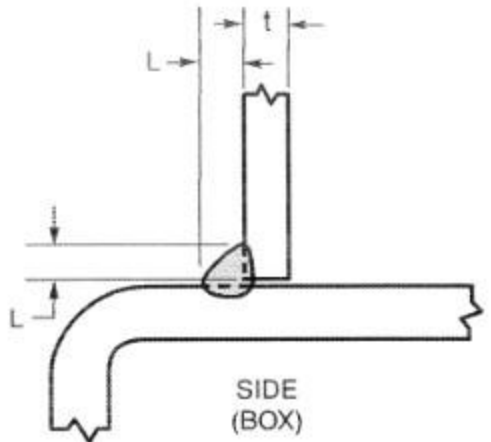
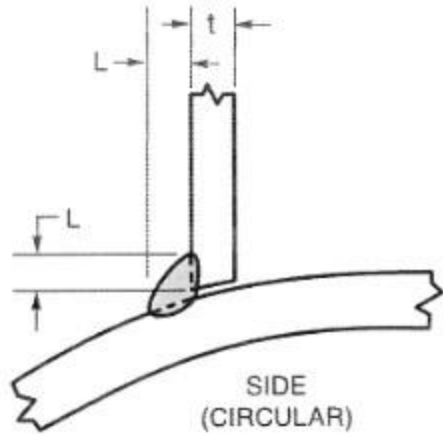
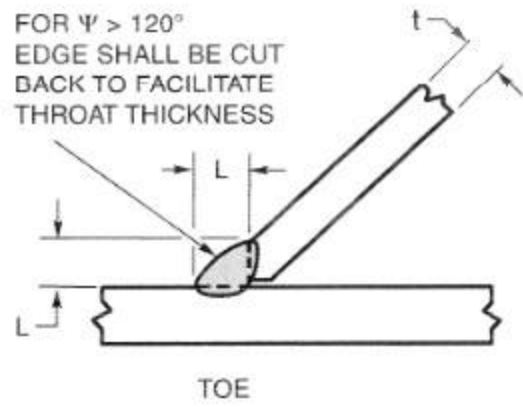

	MIN L FOR		
	$E = 0.7t$	$E = t$	$E = 1.07t$
HEEL $< 60^\circ$	$1.5t$	$1.5t$	LARGER OF $1.5t$ OR $1.4t + Z$
SIDE $\leq 100^\circ$	t	$1.4t$	$1.5t$
SIDE $100 - 110^\circ$	$1.1t$	$1.6t$	$1.75t$
SIDE $110 - 120^\circ$	$1.2t$	$1.8t$	$2.0t$
TOE $> 120^\circ$	t BEVEL	$1.4t$ BEVEL	FULL BEVEL $60-90^\circ$ GROOVE

Notes:

- t = thickness of thinner part.
- L = minimum size (see 10.2.1 which may require increased weld size for combinations other than 36 ksi [250 MPa] base metal and 70 ksi [485 MPa] electrodes).
- Root opening 0 in to 3/16 in [5 mm] (see 7.21).
- Not prequalified for $\phi < 30^\circ$. For $\phi < 60^\circ$, the Z loss dimensions in Table 10.5 apply. See Table 10.12 for welder qualification position requirements.
- See 10.5.2.2 for limitations on $\beta = d/D$.
- Ψ = dihedral angle.