

^aThe backing thickness shall be 1/4 in [6 mm] min. to 3/8 in [10 mm] max.; backing width shall be 3 in [75 mm] min. when not removed for RT, otherwise 1 in [25 mm] min.

Note: When RT is used, no tack welds shall be in test area.

Figure 4.21—Test Plate for Unlimited Thickness—Welder Qualification (see 4.23.1)

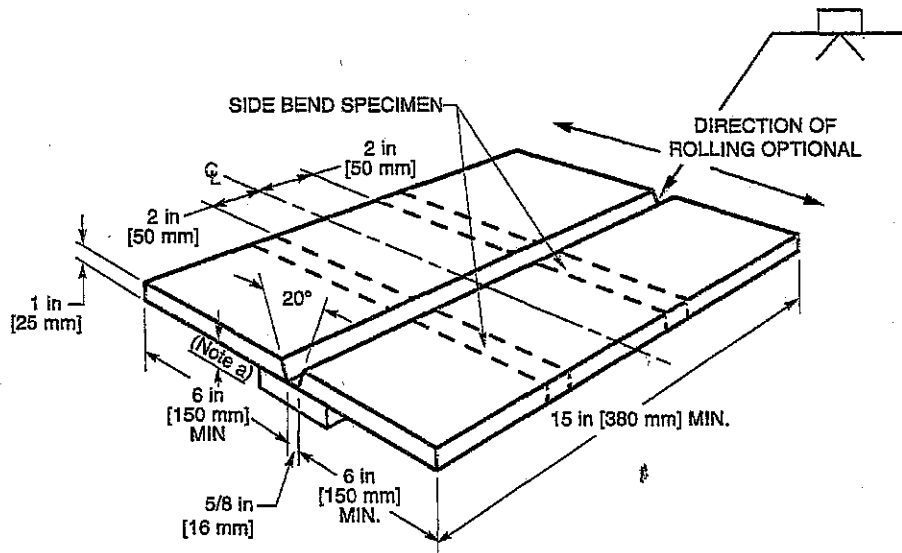

^aThe backing thickness shall be 3/8 in [10 mm] min. to 1/2 in [12 mm] max.; backing width shall be 3 in [75 mm] min. when not removed for RT, otherwise 1-1/2 in [40 mm] min.

Notes:

1. When RT is used, no tack welds shall be in test area.
2. The joint configuration of a qualified WPS may be used in lieu of the groove configuration shown here.

Figure 4.22—Test Plate for Unlimited Thickness—Welding Operator Qualification (see 4.23.2)