

Downloaded by [IP: 128.112.1.10] on [Date: 03/11/16] at [Time: 13:25:00] by [Name:]
 Copyright ASCE, Inc. For all rights reserved. No part of this document may be reproduced, stored in a retrieval system, or transmitted, in any form or by any means, electronic, mechanical, photocopying, recording, or by any information storage and retrieval system, without the prior written permission of ASCE.

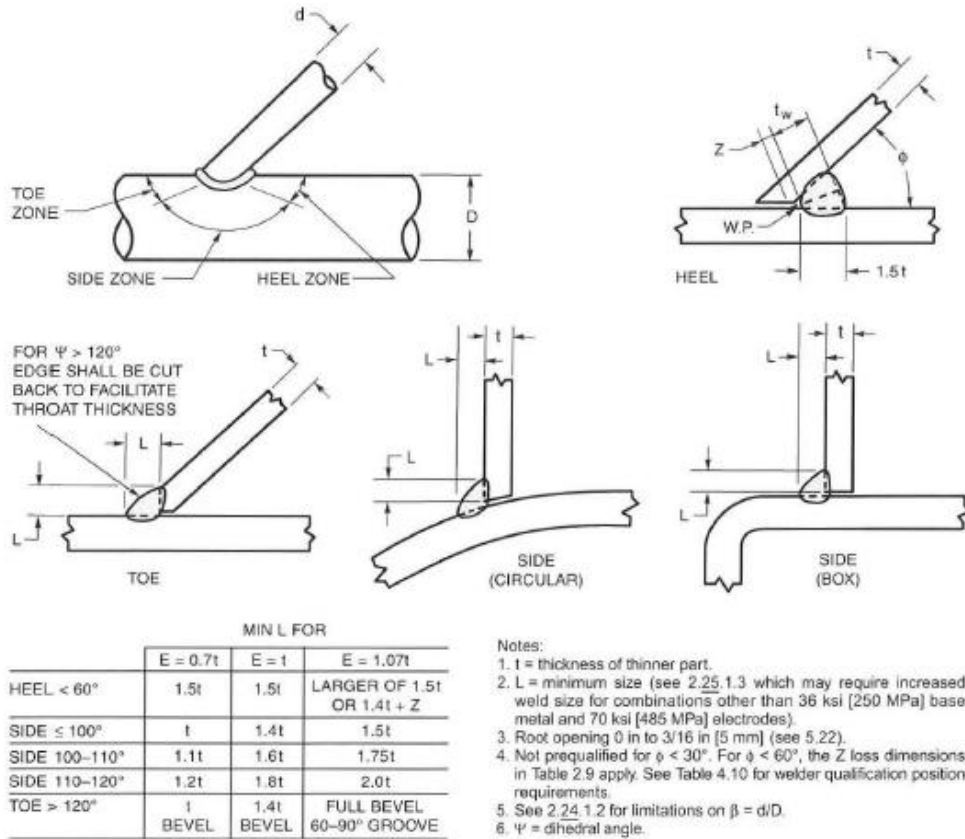

Figure 3.2—Fillet Welded Prequalified Tubular Joints Made by SMAW, GMAW, and FCAW (see 3.9.2)